



MODELO HYDRA PRO

AISI-316

NOVEDAD

KIT DE PIVOTE HIDRÁULICO

Componentes:

- 1 pernio - freno inferior
- 1 pernio alto
- 1 punto de giro superior
- 1 placa de suelo regulable con kit de fijación

Características:

- Vidrio de 8 a 13,52 mm
- Peso máximo puerta: 100 kg
- Ancho máximo puerta: 1000 mm
- Retención a 90°
- Apertura / cierre 180°
- Doble ajuste de velocidad: de 90° a 20° y de 20° a 0°
- Probado en 500.000 ciclos de apertura

Acabados:

Inox brillo	1554 IB
Inox mate	1554 IM
Negro	1554 NE

* Acabados especiales bajo pedido

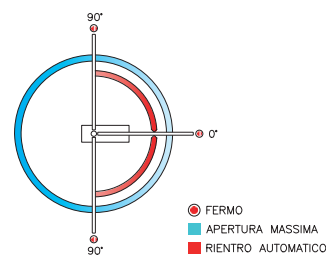

Ver vídeo demostrativo. www.vitrum.es

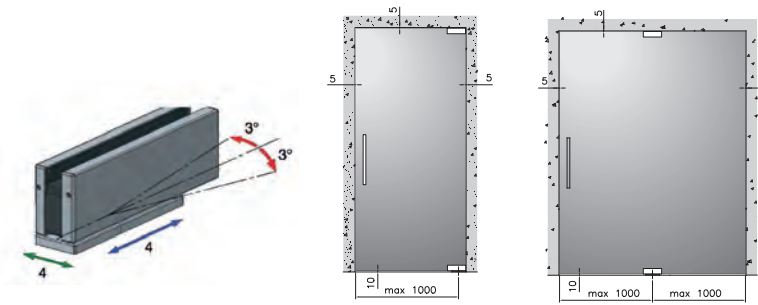

*Para desplazar pernio consultar muesca

PERNIO SUPERIOR

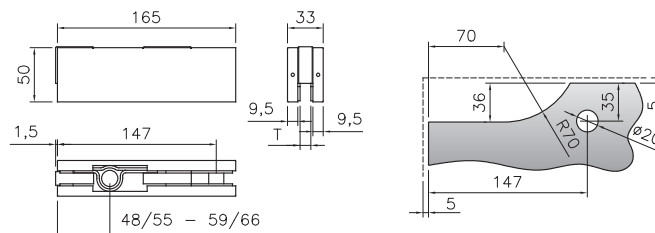

PERNIO INFERIOR

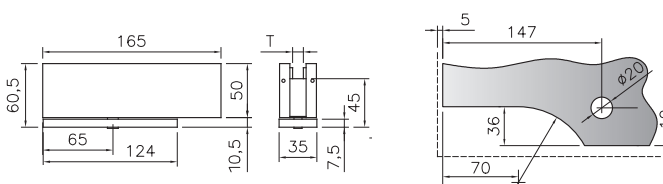

PUNTO DE GIRO

